

T1 File Transfer Protocol (Fcommand)

T1 code after 11/07 (rev. 20.03) contains a protocol for transferring files over the Ockam bus. This protocol is intended to transfer small files, such as sensor correction tables or AutoCal files. It should NOT be used to transfer large or vital files. For that, the compact flash card should be taken out and the files transferred directly.

Warning!

This protocol is hairy and dangerous.
If you mess up a vital file, your T1 will not boot.

Programming model

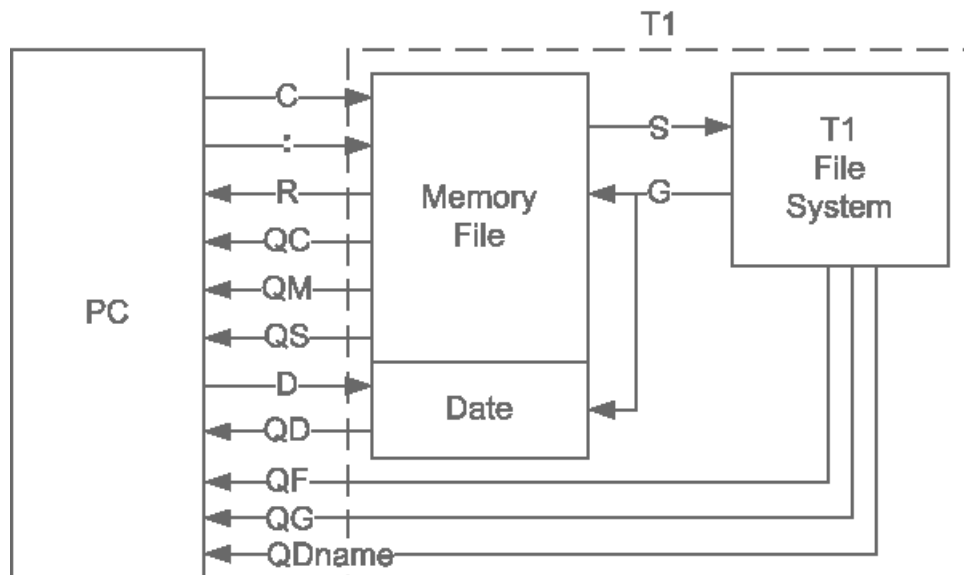

- Memory File** Serves as a file buffer between the PC and the T1. All file transfers pass thru this buffer. The buffer has a maximum size (set by C or G) and a current size (set by G or :).
- Date** When downloading, set by D before Saving. When uploading, set by G to the date of the T1 file transferred to the memory file.
Date is hex 32-bit unsigned integer in DOS date format (yyyyyy mmmm dddd hhhh nnnnn ssss). Y is years since 1980. M, d, h, n are month, day, hour and minute. S is 2*seconds, i.e. 14 is 28 seconds.
- T1 Files** The source or ultimate destination of all file transfers.

Command Summary

PC commands begin with 'F' followed by an action letter and possible data. The first command in a session should be establishing an unused response tag (FTtag) e.g. FTx. This allows the protocol to respond with acknowledgement, errors and data. The protocol responds on the specified tag as shown.

Action	Response	Description
Cbytes (decimal)	F[?error]	Allocates the memory file. When sending a file to the T1, set the memory file greater than the size needed to accept the file. The maximum memory file size is 32768 bytes.
DDOSdate	F[?error]	Sets date of the memory file.
Gname	F[?error]	Load T1 file <name> to memory file. Automatically sizes the memory file large enough to accept the file. The date is also set to the date of the T1 file.
QC	Fchecksum	Returns memory file checksum. Sum of all bytes mod 2 ¹⁶ from 0 to CurMemSize.
QD QDname	FDDOSdate	Returns date of memory file in hex (set by D or G). Returns date of specified file (as of rev 20.10)
QF<name>	F[?7]	Returns blank if <name> exists, otherwise error 7.
QF?<index> Index=0,1,...	F[name]	Enumerates the root directory of the T1. Returns the index th file or blank.
QG<name>	Fsize or F?7	Query the size of a file on the T1 file system (not the memory file). Returned size is decimal.
QM	Fsize	Returns maximum memory file size in hex (set by C or G). Returned size is decimal.
QS	Fsize	Returns current memory file size in hex (set by : or G). Returned size is decimal.
Rccaaaa	F:intelhex	Read memory file. Returns intel hex of length cc beginning at location aaaa. Data is intel hex.
:intelhex	F[?error]	(Colon) Write memory file. Data is intel hex.
S<name>	F[?error]	Save memory file as <name> with date (D subcommand).
T<tag>[']	F	Sets response tag.

Error returns

F?1	Unknown command.
F?2	Bad parameter.
F?3	Unsuccessful memory file allocation.
F?4	Bad checksum.
F?5	No memory file.
F?6	Bad write.
F?7	Bad file open.

Examples

Transferring a file to the T1

In this example, we will be transferring the autocal file (autocal.dat 6218 bytes dated 6/23/05 7:38am) to the T1. Return value is shown within square brackets []. OK response is 'F', errors are 'F?<error>'.

FTx [F]	Set the response tag. All F commands respond with data on this tag. Pick a tag that is not in use. In this example, response is set to tag 'x'. Set a display to this tag to display F command responses.
FC7000 [F]	Set the size of the memory file.
FQFautocal.dat [F] if it exists [F?7] if it doesnt	Check to see if the file already exists on the T1.
FD32D73CC7 [F]	Set the date.
F:08000000010009... F:08000800000064... F:0218480000009E [F] after each record	Send the autocal.dat file as intel hex records. OK, so you don't know how to make intel hex records or type in 15,000 characters. But this is a tutorial.
FQS [F6218]	Check the size of the file.
FQC [FF764]	Check the checksum.
FSautocal.dat [F]	Save the file to the T1. There will be no whinging about overwrite. It will just happen.

Retrieving a file from the T1

In this example, we will transfer the autocal file back from the T1.

FTx [F]	Set the response tag.
FQFautocal.dat [F] if it exists. [F?7] if it doesn't.	Check to see if the file already exists.
FGautocal.dat [F]	Load the file into memory. The memory file size and date are set.
FQD [F32D73CC7]	Retrieve the date.
FR080000 [F08000000010009...]	Retrieve the first intel hex record (8 byte hunks). Repeat until the entire file is uploaded.

Notes

Explanation of the Intel Hex format <http://www.keil.com/support/docs/1584.htm>.